

# 450AJ

## ARTICULATING BOOM LIFT



### Performance

Platform Height	45 ft	13.72 m
Horizontal Outreach	25 ft	7.62 m
Up and Over Height	24 ft	7.3 m
Swing	355 Degrees Non-Continuous	
Platform Capacity Unrestricted	550 lb	249.5 kg
Platform Size	30 x 72 in.	0.76 x 1.83 m
Platform Rotator	180 Degrees Hydraulic	
Jib	4 ft 1 in.	1.24 m
Range of Articulation	144 Degrees (+76, -69)	
Weight	12,650 lb	5,738 kg
Max Ground Bearing Pressure (With Pneumatic Tires)	48 psi	3.37 kg/cm <sup>2</sup>
Drive Speed	4.5 mph	7.24 km/hr
Gradeability	45%	
Axle Oscillation	4 in.	10.16 cm
Turning Radius		
Inside	6 ft 9 in.	2.06 m
Outside	15 ft 8 in.	4.78 m

### Standard Specifications

#### Power Source

Dual Fuel Engine		
GM Vortec 3000 MPFI	82 hp	61 kW
Diesel Engine		
Deutz D2.9 L4 Tier 4 Final	49 hp	36.4 kW
Fuel Tank Capacity	16 gal.	64 L

#### Hydraulic System

System Capacity	38 gal.	143.8 L
Tank Capacity	36 gal.	136.27 L
Auxiliary Power	12V-DC	

#### Tires

Standard	33/1550 x 16.5 Superwide
Optional	12 x 16.5 Lug Tread Tires Foam-Filled Tires Non-Marking Tires



### Standard Features

- 4 ft 1 in. (1.24 m) Articulating Jib
- Platform 30 x 72 in. (0.76 x 1.83 m) Side Entry
- 180 Degree Hydraulic Platform Rotator
- Platform Console Machine Status Light Panel<sup>1</sup>
- 110V-AC Receptacle in the Platform
- 5 Degree Tilt Alarm/Indicator Light
- Swing Out Engine Module
- Improved Multi-Function Controls
- Gull-Wing Turntable Hoods
- 12V-DC Auxiliary Power
- Hourmeter
- Interactive Display at Ground Controls
- Proportional Controls
- Control ADE<sup>®</sup> System
- Lifting/Tie Down Lugs
- Horn
- Four-Wheel Hydrostatic Drive
- Oscillating Axle
- Cast Aluminum Control Box
- Motion Alarm
- Reduced Time to Full Height

### Accessories & Options

- 30 x 60 in. (0.76 x 1.25 m) Platform
- Inward Self-Closing Swing
- 36 x 72 in. (0.91 x 1.83 m) Platform
- Fall Arrest Platform 30 x 60 in. (.76 x 1.53 m)
- Mesh to Top Rail— Bolt-on Aluminum
- 1/2 in. Air Line to Platform
- Soft Touch System
- AC Generator
- Flashing Amber Beacon
- 43.5 lb (19.73 kg) Propane Tank
- Cold Weather Kit<sup>2</sup>
- Arctic Package<sup>4</sup>
- Hostile Environment Kit<sup>3</sup>
- Light Package
- Platform Worklights
- Operator Tool Tray
- Accessory Packages
  - SkyPower<sup>®</sup> Package
  - SkyWelder<sup>®</sup> Package
  - SkyGuard<sup>®</sup>
  - PipeRack

1. Provides indicator lights at platform control console for system distress, low fuel, 5 degree tilt light, and foot switch status.
2. Includes battery blanket, hydraulic tank heater, block heater (GM), glow plugs (Deutz).
3. Includes boom wipers, cylinder bellows and console cover.
4. Includes arctic hydraulic hoses (drive and steer only) and main boom cable, extreme cold engine oil, fuel conditioner, engine block heater, battery blanket, glow plugs, hydraulic tank heater, and oversized footswitch.

Note: Some options may increase lead time, and some option combinations may not be available.

# 450AJ

ARTICULATING BOOM LIFT



## Dimensions

All dimensions are approximate.

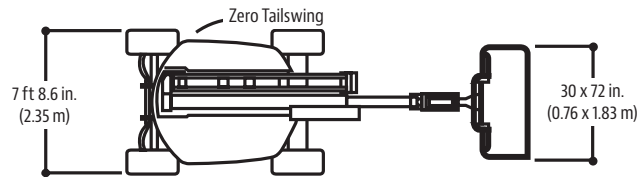
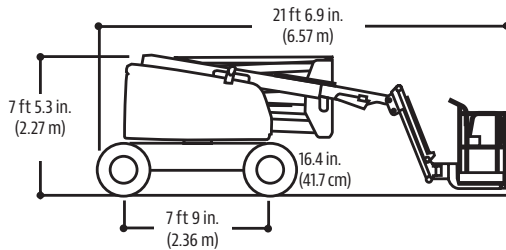

## Reach Diagram

### 450AJ

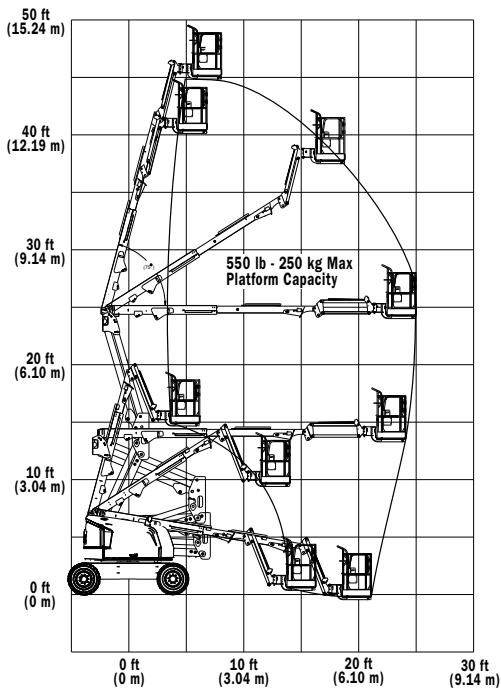

## The JLG "1 & 5" Warranty

JLG Industries, Inc. backs its products with its exclusive "1 & 5" Warranty. We provide coverage on all products for one (1) full year, and cover all specified major structural components for five (5) years. Due to continuous product improvements, we reserve the right to make specification and/or equipment changes without prior notification. This machine meets or exceeds applicable OSHA Regulations in 29 CFR 1910.67, 29 CFR 1926.453, ANSI A92.5-2006, and CSA Standard CAN3-B354.2-M82, as originally manufactured for intended applications.

Part No.: 3131117  
R011512  
Printed in USA



**JLG Industries, Inc.**  
1 JLG Drive  
McConnellsburg, PA 17233-9533  
Telephone 717-485-5161  
Toll-free in US 877-JLG-LIFT  
Fax 717-485-6417  
[www.jlg.com](http://www.jlg.com)

**An Oshkosh Corporation Company**