



MPE-VG

HEAVY DUTY END RIDER

6,000 · 8,000 lbs

Yale® motorized hand trucks incorporate the latest state-of-the-art technology and ergonomic design, making Yale a leader in walkie/rider applications.

Controls

Travel direction and speed are selected by rotating the actuator in the desired direction of travel. The rotary actuator provides multiple grip positions minimizing operator fatigue. The stationary portion of the hand rail minimizes wrist movement and provides a solid grip while maneuvering the truck. The top-mounted handle optimizes operator comfort in the ride position.

Lift, lower, and horn push buttons are conveniently located on the control handle and hand rail to enable use in the walk or ride position.

The Traction Reversing Switch located on top of the handle provides a large area of contact for the operator. When the operator makes contact with the switch the truck simultaneously reverses direction and sounds the horn.

Optional cast aluminum control handle provides full rotary grip traction control. The handle electronics utilize solid state hall effect sensors.

Optional Electronic Power Assist Steer helps the operator easily maneuver the truck with heavy loads through congested loading areas. The amount of assist varies based upon steer angle and truck travel speed.

Optional Smart Coast Control with Pick Assist allows the operator to move the truck forward without having to re-mount the truck and lower the steer handle each time, saving valuable time during pick operations. Single touch coast control can be energized when truck travel speed is at or below 4 mph.

Operator's Compartment

The ergonomically designed padded hand rail and large platform enable operation from either side. The top-mounted handle and hand rail buttons provide intuitive control of travel, steering, lift/lower and the horn. The soft touch hand rail provides a place for the operator to grab when stepping on to the platform as well as providing stability when driving the truck. The auxiliary controls located on the hand rail are designed to minimize movement of the hand to actuate the various functions. This design adds to operator stance stability.

A thick removable cushioned floor mat absorbs road shock and reduces operator fatigue.

Electrical System

The electrical system utilizes AC drive technology designed for exceptional performance. High starting torque and smooth acceleration

are benefits of this technology. A speed sensor built into the motor provides feedback to the control system, allowing motor speed and direction to be continuously monitored. The MPE provides industry leading acceleration and a top speed up to 9 mph.

CANbus Communication

CANbus technology streamlines communications between truck systems. The control handle, controller, display and optional power assist steer communicate via the CANbus network. CANbus reduces wiring and electrical connections.

A Thermal Management System continuously monitors traction motor and motor controller temperatures. If necessary, the system gradually adjusts performance to protect truck systems.

AC Traction System

The traction system consists of the traction motor, gearbox and brake. The innovative gearbox design incorporates maintenance-free permanently lubricated steer bearings. A stationary mounted traction motor eliminates power cable tension and flex. Quiet integrated motor pinion and support bearings optimize gear mesh, while a splined coupling allows for quick removal and installation of the traction motor.

The electrically released/mechanically applied brake is mounted on the top of the traction motor for ease of inspection and service.

The **drive axle string guard** minimizes axle seal damage from shrink-wrap, banding, etc.

The **on-board software** allows certified personnel access to programming, test and diagnostic functions without the need of a handset or special tools. More in-depth programming can be performed by the servicing dealer using a PC service tool. Certified technicians can customize the performance of the truck to meet the customer's particular application. The truck features four operator selectable modes and two master level performance settings.

Hydraulic Components

The high performance transistorized controlled hydraulic system is designed for high cycle, multi-shift operations. The hydraulic pump and motor assembly provides high torque and low noise. The translucent tank provides quick and easy inspection of hydraulic oil level.

Heavy Duty Forks and Frame

The heavy-duty cycle components are designed for multi-shift applications and low operating costs. The wide cast steel lift cylinder support evenly distributes stresses from heavy pallets. The boxed-in forks and reinforced fork tips are designed for maximum rigidity and minimal fork flex. Heavy duty castings relieve stress at critical pivot points.

Heavy Duty Linkage

Hardened flag linkage pins are bolt retained for ease of serviceability and low cost of operation. Heavy duty pull rods with center welded threaded insert provide ease of adjustment and shock absorption. All pivot points have "X" groove style bushings and are greasable. Critical linkage components are made from durable cast material for maximum durability and lowest cost of operations. Advanced lift geometry reduces pivot point stress points.

Pallet Entry and Exit

The standard fork tip utilizes a carburized steel blade to hold down and climb pallet bottom boards for easy entry. The extended length exit runners coupled with large exit rollers provides for a smooth transition out of pallets.

Drive Tire and Stability Casters

A simple 5-bolt pattern retains the drive wheel assembly to the axle hub. The Heavy Duty Quick Adjust Casters are Urethane block loaded (optional on MPE060VG, standard on MPE-080VG). Its unique sloped profile is designed to glide over impact areas. The HD caster is greasable and rebuildable.



GENERAL	1	Manufacturer		Yale®				
	2	Model Designation		MPE060VG				
	3	Power Type		24 Volt				
	4	Operator Type		Stand Ride				
DIMENSIONS	5	Rated Capacity		lb. (kg)	6000 (2722)			
	6	Fork Length	Nominal	in. (mm)	36 (914)	42 (1067)	48 (1219)	54 (1372)
			Actual	in. (mm)	35.7 (908)	41.8 (1061)	47.8 (1213)	53.7 (1365)
	7	Fork Overall Width		in. (mm)	27.1 (688)			
	8	Fork Width	Individual Fork	in. (mm)	9.1 (232)			
	9	Load Distance (Face of Battery Box to Center of Load Wheels)	Raised	in. (mm)	23.3 (591)	29.3 (744)	35.3 (896)	41.3 (1048)
			Lowered	in. (mm)	27.6 (702)	33.6 (854)	39.6 (1007)	45.6 (1159)
	10	Wheelbase	Raised	in. (mm)	51.3 (1303)	57.3 (1455)	63.3 (1608)	69.3 (1760)
			Lowered	in. (mm)	55.1 (1400)	61.1 (1552)	67.1 (1705)	73.1 (1857)
	11	Overall Length	Raised	in. (mm)	78.2 (1987)	84.2 (2139)	90.2 (2292)	96.2 (2444)
			Lowered	in. (mm)	77.7 (1974)	83.7 (2126)	89.7 (2279)	95.7 (2431)
	12	Center of Load Wheel to Tip of Forks	Raised	in. (mm)	12.5 (317)			
	13		Lowered	in. (mm)	8.1 (206)			
	14	Outside Turning Radius	Raised	in. (mm)	65.7 (1670)	71.8 (1823)	77.8 (1975)	83.8 (2128)
			Lowered	in. (mm)	69.6 (1768)	75.6 (1920)	81.6 (2073)	87.6 (2225)
	15	Right Angle Stack	Raised	in. (mm)	81.6 (2073)	N/A	92.1 (2340)	N/A
	16	Equal Intersecting Aisle	Raised	in. (mm)	63.0 (1599)	N/A	69.2 (1757)	N/A
	17	Grade Clearance	Chassis	%	28			
			Center of Wheelbase	%	39	34	31	28
			Forks	%	37			
	18	Overall Lift Height	Top of Forks	in. (mm)	9.3 (235)			
	19	Lowered Height	Top of Forks	in. (mm)	3.3 (84)			
	20	Total Lift		in. (mm)	5.9 (151)			
21	Truck Overall Width		in. (mm)	36.9 (937)				
22	Chassis Length	Raised	in. (mm)	42.5 (1079)				
		Lowered	in. (mm)	42.0 (1066)				
23	Battery Compartment (Standard / With Battery Rollers)			32.0 x 13.4 x OPEN (813 x 340 x OPEN)				
PERFORMANCE	24	Max. Travel Speed - Chassis First	No Load / Rated Load	mph (kph)	9.0 / 6.7 (14.5 / 10.8)			
	25	Max. Travel Speed - Forks First	No Load / Rated Load	mph (kph)	6.0 / 6.0 (9.7 / 9.7)			
	26	Number of Speeds			Infinitely Variable			
	27	Traction Motor Control Method	Type		AC Transistor			
28	Service Brake	Type		Electro-Mechanical				
WT.	29	Truck Weight (approx.) w/o Battery	No Load / Rated Load	lb. (kg)	1378.0 / 7379.0 (625.0 / 3347.0)	1429.0 / 7430.0 (648.0 / 3370.0)	1473.0 / 7474.0 (668.0 / 3390.0)	1519.0 / 7520.0 (689.0 / 3411.0)
	30	Axle Loading - Drive: Static with Maximum Wt. Battery (No Load)		lb. (kg)	1731 (785)	1823 (827)	1903 (863)	1997 (906)
	31	Axle Loading - Load Wheels (combined): Static w/Maximum Wt. Battery (No Load)		lb. (kg)	798 (362)	750 (340)	714 (324)	666 (302)
WHEELS	32	Drive Tire: Size / Type (Number of Wheels)		in.	12.0 x 4.5 x 8.0 / Polyurethane (1)			
	33	Load Wheel: Size / Type (Number of Wheels) (# of Bearings)		in.	3.25" x 6.5" / Polyurethane (2) (2)			
	34	Caster Wheel: Size / Type (Number of Wheels) Caster Type		in.	4.0' x 2.5" / Polyurethane (2) Spring Loaded			
BATTERY	35	Type			Lead Acid			
	36	Ampere Hours - Maximum		ah	930			
	37	Ampere Hours - Minimum		ah	375			
	38	Maximum Weight		lb. (kg)	1500 (680)			
	39	Minimum Weight		lb. (kg)	540 (245)			

Above specifications, unless otherwise listed, are for a standard truck without optional equipment.

Right Angle Stack and Equal Intersecting Aisle are calculated using a 40" wide pallet.

Grade Clearance measured to the bottom of the pallet with forks in a raised position.

Yale®					Yale®	
MPE060VG					MPE080VG	
24 Volt					24 Volt	
Stand Ride					Stand Ride	
6000 (2722)					8000 (3629)	
60 (1524)	96 (2438)	84 (2134)	93 (2362)	96 (2438)	36 (914)	42 (1067)
59.8 (1518)	95.7 (2432)	83.7 (2127)	92.8 (2356)	95.7 (2432)	35.7 (908)	41.8 (1061)
27.1 (688)					27.1 (688)	
9.1 (232)					9.1 (232)	
47.3 (1201)	83.3 (2115)	56.3 (1430)			23.3 (591)	29.3 (744)
51.7 (1312)	87.6 (2226)	60.6 (1540)			27.6 (702)	33.6 (854)
75.3 (1912)	111.3 (2827)	84.3 (2141)			51.3 (1303)	57.3 (1455)
79.1 (2010)	115.1 (2924)	88.1 (2238)			55.1 (1400)	61.1 (1552)
102.2 (2597)	138.2 (3511)	126.2 (3206)	135.2 (3435)	138.2 (3511)	78.2 (1987)	84.2 (2139)
101.7 (2583)	137.7 (3498)	125.7 (3193)	134.7 (3422)	137.7 (3498)	77.7 (1974)	83.7 (2126)
12.5 (317)		27.4 (697)	36.5 (926)	39.4 (1002)	12.5 (317)	
8.1 (206)		23.1 (587)	32.1 (816)	35.1 (892)	8.1 (206)	
89.8 (2280)	125.7 (3194)	98.8 (2509)			65.7 (1670)	71.8 (1823)
93.6 (2377)	129.6 (3292)	102.6 (2606)			69.6 (1768)	75.6 (1920)
N/A	136.9 (3478)	141.1 (3583)			81.6 (2073)	N/A
N/A	94.4 (2397)	82.2 (2089)			63.0 (1599)	N/A
28					27	
26	17	23			38	34
37		17	12	11	37	
9.3 (235)					9.3 (235)	
3.3 (84)					3.3 (84)	
5.9 (151)					5.9 (151)	
36.9 (937)					36.9 (937)	
42.5 (1079)					42.5 (1079)	
42.0 (1066)					42.0 (1066)	
32.0 x 13.4 x OPEN (813 x 340 x OPEN)					32.0 x 13.4 x OPEN (813 x 340 x OPEN)	
9.0 / 6.7 (14.5 / 10.8)					9.0 / 6.0 (14.5 / 9.7)	
6.0 / 6.0 (9.7 / 9.7)					6.0 / 6.0 (9.7 / 9.7)	
Infinitely Variable					Infinitely Variable	
AC Transistor					AC Transistor	
Electro-Mechanical					Electro-Mechanical	
1563.0 / 7564.0 (709.0 / 3431.0)	1887.0 / 7888.0 (856.0 / 3578.0)	1682.0 / 7683.0 (763.0 / 3485.0)	1737.0 / 7738.0 (788.0 / 3510.0)	1768.0 / 7769.0 (802.0 / 3524.0)	1400.0 / 9401.0 (635.0 / 4264.0)	1451.0 / 9451.0 (658.0 / 4287.0)
2090 (948)	2679 (1215)	2196 (996)	2249 (1020)	2295 (1041)	1814 (823)	1834 (832)
617 (280)	353 (160)	628 (285)	631 (286)	617 (280)	732 (332)	754 (342)
12.0 x 4.5 x 8.0 / Polyurethane (1)					12.0 x 4.5 x 8.0 / Polyurethane (1)	
3.25" x 6.5" / Polyurethane (2) (2)		3.25" x 5.6" / Vulkollan (2) (2)			3.25" x 6.5" / Polyurethane (2) (4)	
4.0' x 2.5" / Polyurethane (2) Spring Loaded					4.0' x 2.5" / Polyurethane (2) Urethane Block Loaded	
Lead Acid					Lead Acid	
930					930	
375					375	
1500 (680)					1500 (680)	
540 (245)					540 (245)	

Yale®							1	GENERAL
MPE080VG							2	
24 Volt							3	
Stand Ride							4	
8000 (3629)							5	
48 (1219)	54 (1372)	60 (1524)	84 (2134)	93 (2362)	96 (2438)	144 (3658)	6	
47.8 (1213)	53.7 (1365)	59.8 (1518)	83.8 (2128)	92.8 (2357)	95.8 (2433)	143.8 (3652)		
27.1 (688)			28.0 (710)			28.6 (726)	7	
9.1 (232)			10.0 (254)			10.6 (270)	8	
35.3 (896)	41.3 (1048)	47.3 (1201)	56.3 (1430)			104.3 (2649) 83.9 (2131)	9	
39.6 (1007)	45.6 (1159)	51.7 (1312)	60.6 (1540)			108.6 (2759) 87.7 (2228)		
63.3 (1608)	69.3 (1760)	75.3 (1912)	84.3 (2141)			132.3 (3360) 111.4 (2829)	10	
67.1 (1705)	73.1 (1857)	79.1 (2010)	88.1 (2238)			136.1 (3457) 115.2 (2926)		
90.2 (2292)	96.2 (2444)	102.2 (2597)	126.3 (3207)	135.3 (3436)	138.3 (3512)	186.3 (4731)	11	
89.7 (2279)	95.7 (2431)	101.7 (2583)	125.7 (3194)	134.8 (3423)	137.8 (3499)	185.7 (4718)		
12.5 (317)		12.5 (317)	27.5 (698)	36.5 (927)	39.5 (1003) 59.9 (1521)		12	
8.1 (206)			23.1 (588)	32.2 (817)	35.2 (893) 56.1 (1424)		13	
77.8 (1975)	83.8 (2128)	89.8 (2280)	98.8 (2509)			146.8 (3728) 125.9 (3197)	14	
81.6 (2073)	87.6 (2225)	93.6 (2377)	102.6 (2606)			150.6 (3825) 129.7 (3294)		
92.1 (2340)	N/A		141.1 (3583)			186.9 (4746) 187.8 (4770)	15	
69.2 (1757)	N/A		82.2 (2089)			106.9 (2716) 98.7 (2506)	16	
27							17	
30	27	26	22			14 17		
37			17	13	12	8		
9.3 (235)							18	
3.3 (84)							19	
5.9 (151)							20	
36.9 (937)							21	
42.5 (1079)							22	
42.0 (1066)								
32.0 x 13.4 x OPEN (813 x 340 x OPEN)							23	
9.0 / 6.0 (14.5 / 9.7)							24	
6.0 / 6.0 (9.7 / 9.7)							25	
Infinitely Variable							26	
AC Transistor							27	
Electro-Mechanical							28	
1495.0 / 9495.0 (678.0 / 4307.0)	1541.0 / 9542.0 (699.0 / 4328.0)	1585.0 / 9586.0 (719.0 / 4348.0)	1704.0 / 9705.0 (773.0 / 4402.0)	1759.0 / 9760.0 (798.0 / 4427.0)	1790.0 / 9791.0 (812.0 / 4441.0)	2154.0 / 10154.0 (977.0 / 4606.0) 2134.0 / 10134.0 (968.0 / 4567.0)	29	
1916 (869)	2011 (912)	2103 (954)	2211 (1003)	2264 (1027)	2313 (1049)	2624 (1190) 2624 (1190)	30	
719 (326)	670 (304)	622 (282)	633 (287)	635 (288)	621 (282)	661 (300) 661 (300)	31	
12.0 x 4.5 x 8.0 / Polyurethane (1)							32	
3.25" x 6.5" / Polyurethane (2) (4)							33	
4.0' x 2.5" / Polyurethane (2) Urethane Block Loaded							34	
Lead Acid							35	
930							36	
375							37	
1500 (680)							38	
540 (245)							39	
							WT.	
							WHEELS	
							BATTERY	

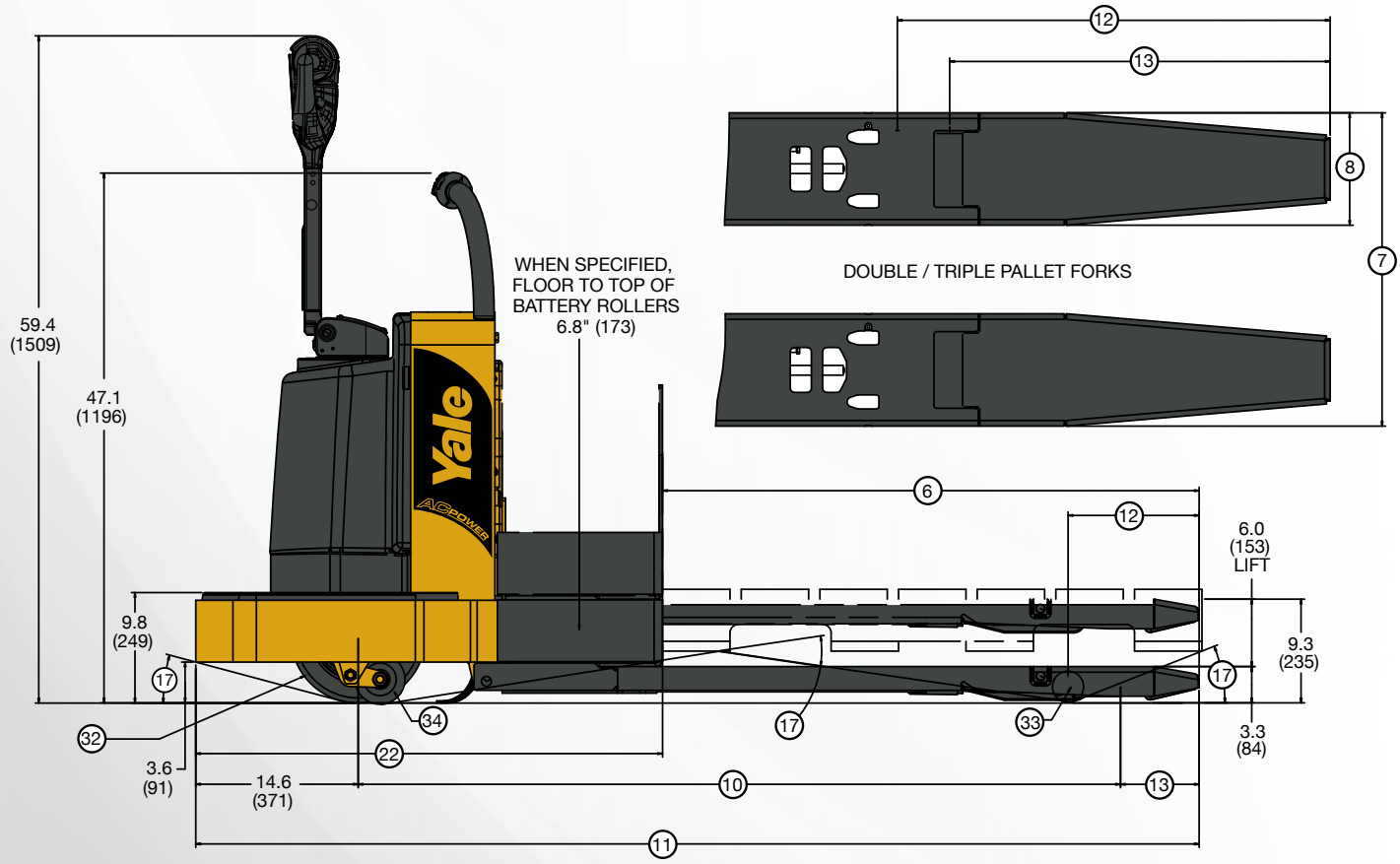
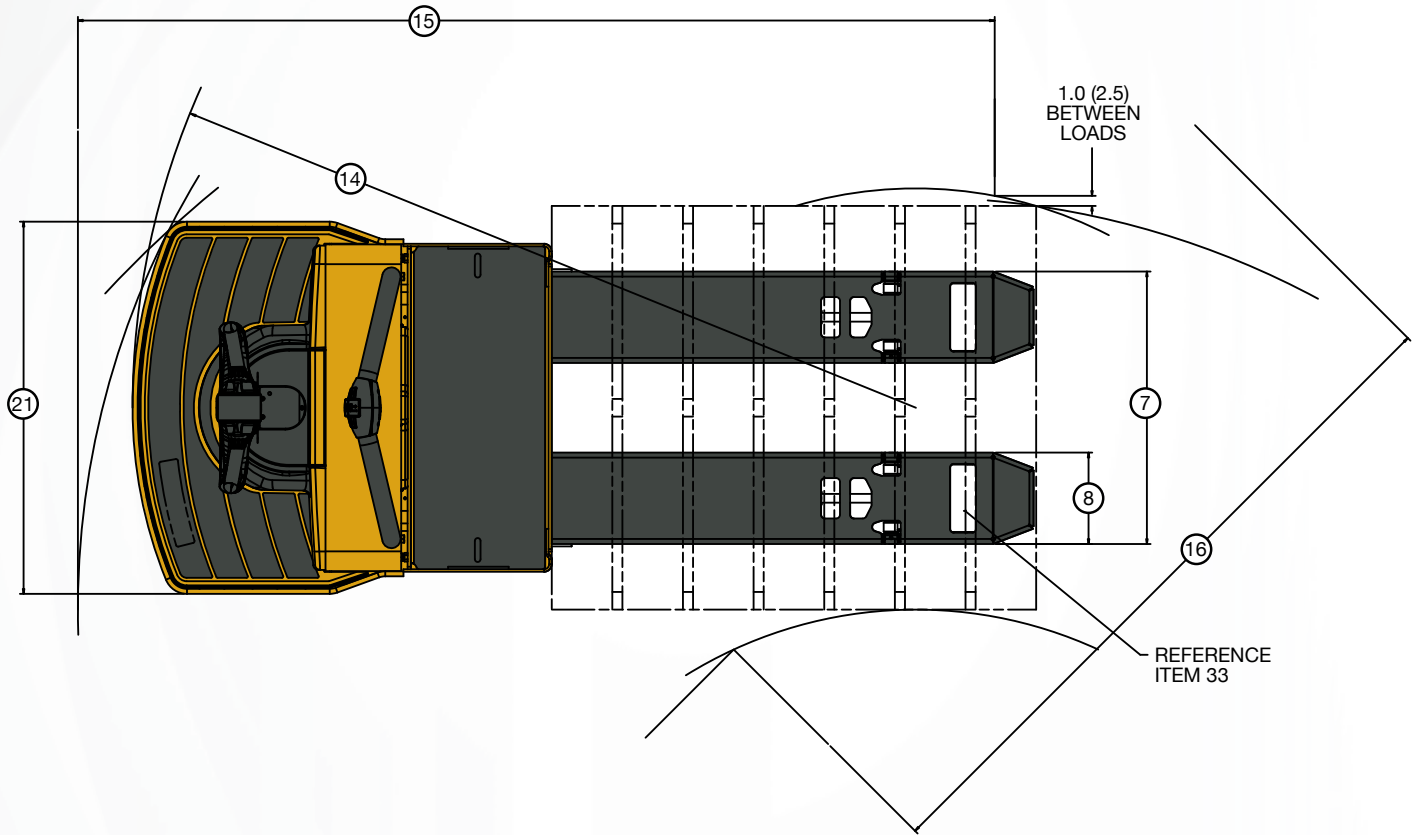

Circled dimensions correspond to the line numbers on the tabulated chart inside the spec sheet. Dimensions are in inches (millimeters).

Battery and Compartment Specifications							
Number of Cells	Cell Size	Plates per Cell	Capacity 6 Hour Rate	Battery Dimensions			Max. Weight
				"X"	"Y"	"Z"	
				amp hr (kwh)	in. (mm)	in. (mm)	in. (mm)
12	75	11	375 (8.7)	26.5 (673)	13.0 (330)	23.3 (592)	825 (374)
12	85	11	425 (9.9)	26.1 (663)	13.0 (330)	23.3 (592)	865 (392)
12	75	13	450 (10.5)	30.9 (785)	13.0 (330)	23.3 (592)	987 (448)
12	85	13	510 (11.9)	30.9 (785)	13.0 (330)	23.3 (592)	1035 (469)
12	100	13	600 (14.0)	30.9 (785)	13.0 (330)	26.2 (665)	1200 (544)
12	125	13	750 (17.6)	30.9 (785)	13.0 (330)	31.0 (787)	1500 (680)
12	155	13	930 (21.5)	30.9 (785)	13.0 (330)	31.0 (787)	1500 (680)

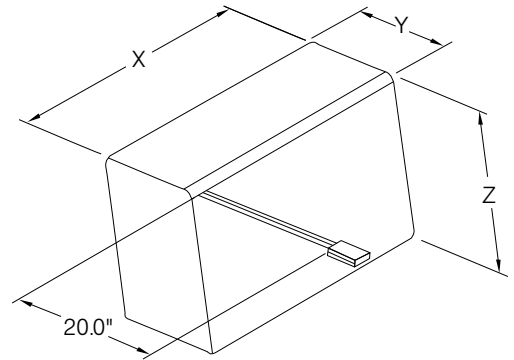

- (1) Battery Connector: SB 175 Amp Red - Standard / SB 175 Amp Grey - Optional
 (2) Battery Lead: Length 20" (508mm), Position "B", 1/0 AWG
 (3) Battery Cover Required

Options

- UL Classification Type EE
- Electronic power assist steering
- Battery rollers
- Cast aluminum control handle with rotary grip / butterfly travel control
- Convenience tray (load backrest mounted or battery mounted)
- Rf terminal power supply – 24 volt
- Audible alarm
- Visible alarm – pole mounted amber strobe
- Advanced coast control with side glide
- Manual coast control with side glide
- Stability casters
 - Heavy duty – greasable wheel (std on MPE080VG)
 - Heavy duty – sealed wheel
- Fork lengths
 - 36" long forks – standard tip
 - 42" long forks – standard tip
 - 54" long forks – standard tip
 - 60" long forks – standard tip
 - 96" long forks – standard tip (MPE080VG only)
 - 84" long forks – extended tip
 - 93" long forks – extended tip
 - 96" long forks – extended tip
 - 144" long forks – extended tip (MPE080VG only)
 - 144" long forks – short wheelbase extended tip (MPE080VG only)
- Drive tire
 - MPE060VG
 - Rubber – 65 durometer, 10" X 5.0"
 - Red polyurethane – 85 durometer, 10" X 5.0"
 - Vulkollan polyurethane – 90 durometer, 10" X 5.0"
 - MPE080VG
 - Soft polyurethane – 80 durometer, 12" X 4.5"
 - Red polyurethane – 85 durometer, 12" X 4.5"
 - Vulkollan polyurethane – 90 durometer, 12" X 4.5"
- Load wheels
 - Single and dual
 - 2 bearing and 4 bearing
 - Standard bearing and sealed bearing
- Load backrest
 - 48" high (pivoting or bolt-on)
 - 60" high (pivoting or bolt-on)
 - 72" high (bolt-on)
- Application/Environmental Construction
 - Cooler/Freezer Package:
 - Operating temperatures: 0° F to +120° F
 - SUBZERO Freezer Package:
 - Operating temperatures: -40° F to +120° F
 - Wash Down Package:
 - Operating temperatures: 0°F to +120°F
 - Extreme Corrosion Wash Down Package:
 - Operating temperatures: 0°F to +120°F



YALE MATERIALS HANDLING CORPORATION
 P.O. Box 7367, Greenville, NC 27835-7367
www.yale.com

Yale is a Registered Trademark and  is a Registered Copyright.
 ©Yale Materials Handling Corporation 2014. All Rights Reserved.

Manufactured in our own ISO 9001 and 14001 Registered Facilities

Truck performance may be affected by the condition of the vehicle, how it is equipped and the application. Consult your Yale® Industrial Truck Dealer if any of the information shown is critical to your application. Specifications are subject to change without notice.

This truck meets all applicable mandatory requirements of ANSI B56.1 Safety Standard for Powered Industrial Trucks at the time of manufacture. Classified by Underwriters' Laboratories, Inc., as to fire and electric shock hazard only for Type E industrial trucks.

The Yale® products included in this document may be covered by US patent 6,684,148 and other patents pending.